

TU Delft Workshop

# Reproducible Research in Signal Processing: How to Increase Impact

---

*Patrick Vandewalle*

*June 9, 2011*

*Joint work with M. Vetterli and J. Kovacevic*



# Introduction

---

**Based on recent paper  
in IEEE Signal Processing  
Magazine \***



## Reproducible Research in Signal Processing

[What, why, and how]

[Patrick Vandewalle, Jelena Kovačević, and Martin Vetterli]

**H**ave you ever tried to reproduce the results presented in a research paper? For many of our current publications, this would unfortunately be a challenging task. For a computational algorithm, details such as the exact data set

the same results. In our experience, it is often even worse as even we are not always able to reproduce our own experiments, making it difficult to answer questions from colleagues about details. Following are some examples of e-mails we have received:

---

\* P. Vandewalle, J. Kovacevic and M. Vetterli, *Reproducible Research in Signal Processing - What, Why, and How*, IEEE Signal Processing Magazine, 2009.

# Introduction: A Bit of History

---

- *The Royal Society celebrates its 350<sup>th</sup> anniversary!* \*  
Results and experiments should be described so that other researchers can reproduce them.
  - peer reviewed journals
  - scientific culture as we know it today

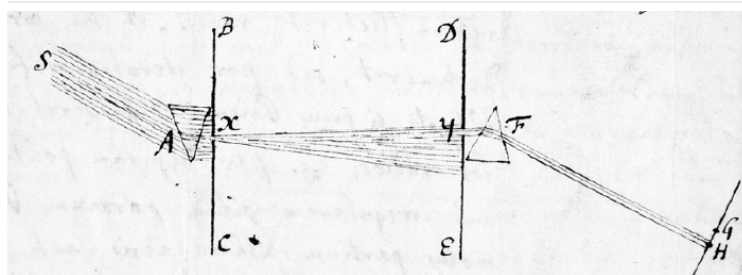

Isaac Newton's diagram of an experiment on light with two prisms. From a letter to the Royal Society, 6th June 1672.

© The Royal Society



- Invention of printing: Transformed alchemy into chemistry...
- Invention of web: Should have a similar transformational role!

\* <http://350.royalsociety.org/> and <http://trailblazing.royalsociety.org/>

# Introduction: A Bit of History

---

- Worries about reproducibility are centuries old
  - Discourse on (Scientific) Method, Descartes, 1637
  - Literate Programming, D. Knuth, 1984
    - “Instead of imagining that our task is to instruct a computer what to do, let us concentrate rather on explaining to human beings what we want a computer to do.”*
  - And many more, in various disciplines
- Long list of non-reproducible works getting a lot of (negative) media attention
  - Fermat’s last theorem
  - Stem cell research, 2006
  - Climategate scandal, 2009
  - ...

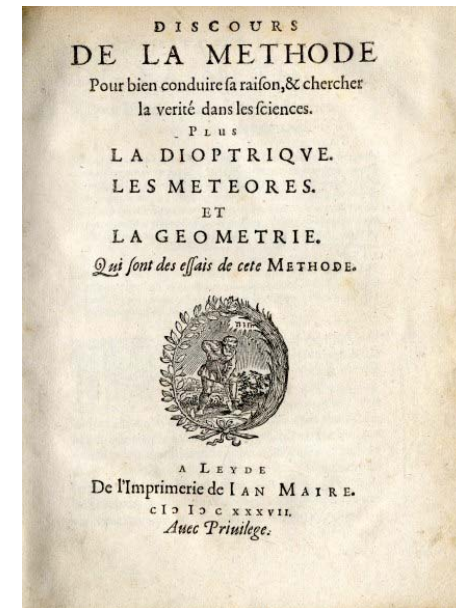

# Introduction: A Bit of History

---

## Reproducible research in computational sciences

- Claerbout, SEP, Stanford (1990)
  - Makefiles to build and clean results
- Donoho, Statistics Department, Stanford (1995)
  - WaveLab using Matlab

*“An article about computational science in a scientific publication is not the scholarship itself, it is merely advertising of the scholarship. The actual scholarship is the complete software development environment and the complete set of instructions which generated the figures.”*

- Various other domains
  - Econometrics, Neurophysiology, Epidemiology



**WAVELAB 850**

Home Download Documentation Registration Links Contact Acknowledgements

Continuous Wavelet Transform of Center Signal

WaveLab is a collection of Matlab functions that have been used by the authors and collaborators to implement a variety of algorithms related to wavelet analysis. A partial list of the techniques made available:

- orthogonal and biorthogonal wavelet transforms,
- translation-invariant wavelets,
- interpolating wavelet transforms,
- cosine packets,
- wavelet packets,
- matching pursuit,

and a lot more: [Here is a more detailed introduction.](#)

**Philosophy—why do it?**

WaveLab implements the concept of [reproducible research](#).

The idea is: An article about computational science in a scientific publication is **not** the scholarship itself, it is merely **advertising** of the scholarship. The actual scholarship is the complete software development environment and the complete set of instructions which generated the figures.

# Introduction

---

## Some examples from day to day practice

I just read your paper X. It is very completely described, however I am confused by Y. Could you provide the implementation code to me for reference if possible?

Hi! I am also working on a project related to X. I have implemented your algorithm, but cannot get the same results as described in your paper. Which values should I use for parameters Y and Z?

Graduate student to professor: “My algorithm works better than the best published one, I assure you!”

# Introduction

---

## Definition

*“Reproducibility is one of the main principles of the scientific method, and refers to the ability of a test or experiment to be accurately reproduced, or replicated, by someone else working independently.”*

- Wikipedia -

# Motivations

---

## **It is a fundamental principle of the research culture**

- 350 years and going strong
- It is the Lego principle!

## **Research self-discipline**

- More efficient
- More 'robust'

## **Advantages**

- Allows you to continue where you left work
- Allows others to start from the same point
- Allows others to use your work as a building block
- Increases impact

# Related Work

---

## Research practices in other domains

- Mathematics
  - ‘Reprovable’, proofs can be verified
  - Not reproducible: Fermat’s last theorem
    - “J’ai trouvé une merveilleuse démonstration de cette proposition, mais je ne peux l’écrire dans cette marge car elle est trop longue.”*
- Exact Sciences (Physics, Chemistry, etc.)
  - Experimental setups
- Life Sciences
  - Experimental setups
  - Other researchers repeat experiments
  - Journal of Cell Biology checks for image manipulation

→ Computational sciences have a lot to learn!

# Related Work

---

Signal processing:

- Between applied mathematics and engineering applications
- Benefits by making results as reproducible as possible
  - helps the research itself
  - increases impact and visibility of the research
  - plain good practice

# Components of Signal Processing Research

---

## Theory

- Well described theorems and proofs
- Numerical simulations are very helpful

*Example: Spectrum of Ultra-Wide Band (UWB) Signals [Ridolfi et al]*

$$S_X(\nu) = |\hat{w}(\nu)|^2 \lambda \left( 2\text{Re} \left\{ \sum_{k \geq 0} \phi_S^k(2\pi\nu) \right\} d\nu - 1 - \lambda\delta(\nu) \right).$$

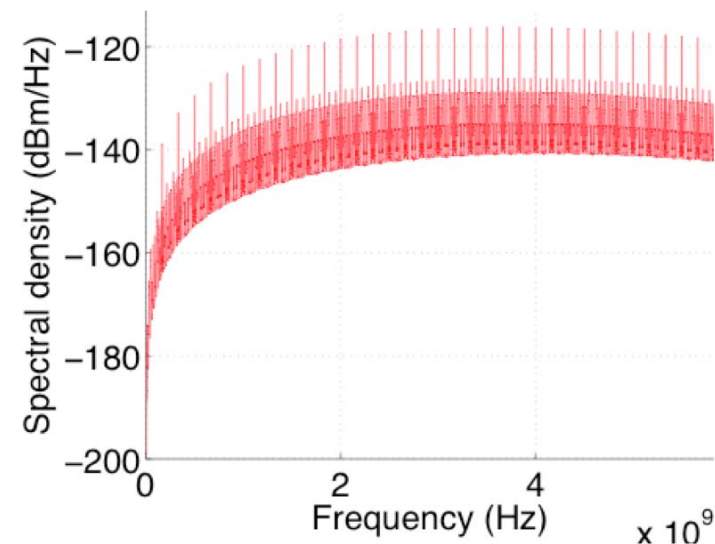

Andrea Ridolfi and Moe Z. Win, *Ultrawide Bandwidth Signals as Shot-Noise: a Unifying Approach*, IEEE Journal on Selected Areas of Communications, Vol. 24, Nr. 4, pp. 899-905, 2006.

# Components of Signal Processing Research

## Algorithms

- Code
- Data
- Environment
  - Computer platform
  - Compiler and compiler flags
  - Software version
  - User interface, if available

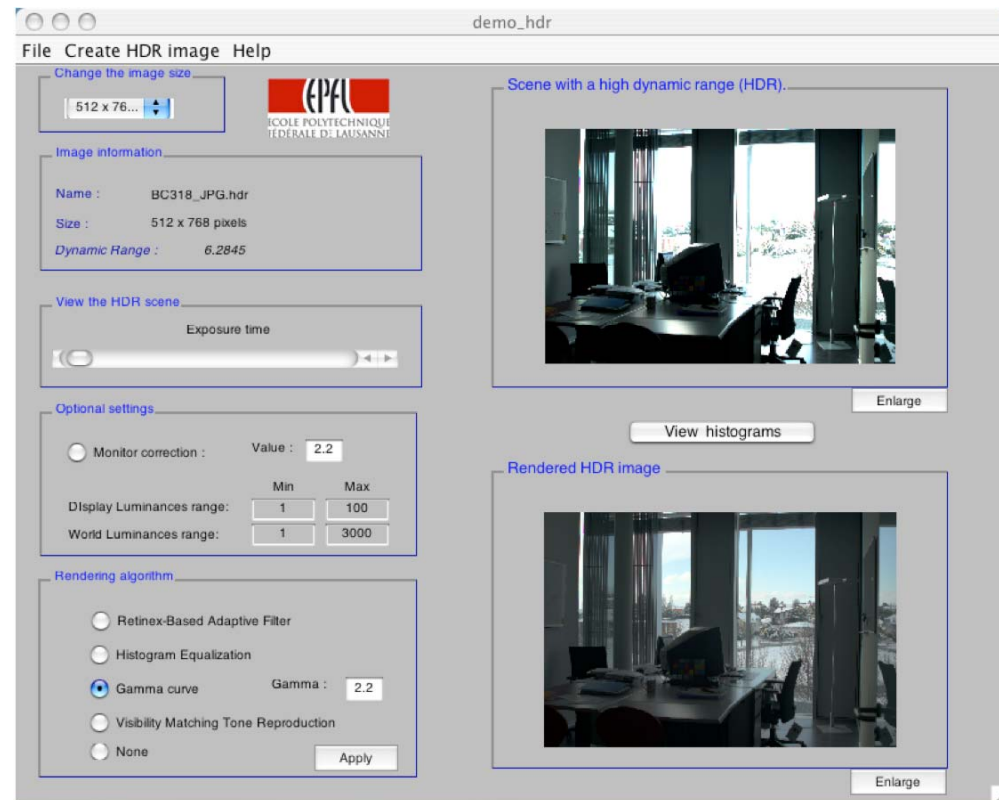

L. Meylan and S. Ssstrunk, *High Dynamic Range Image Rendering Using a Retinex-Based Adaptive Filter*, IEEE Transactions on Image Processing, 2006.

# Components of Signal Processing Research

## Data and Experimental Setups

- Measurement setup
- Setup or calibration procedures
- Complex setups: reusable data sets

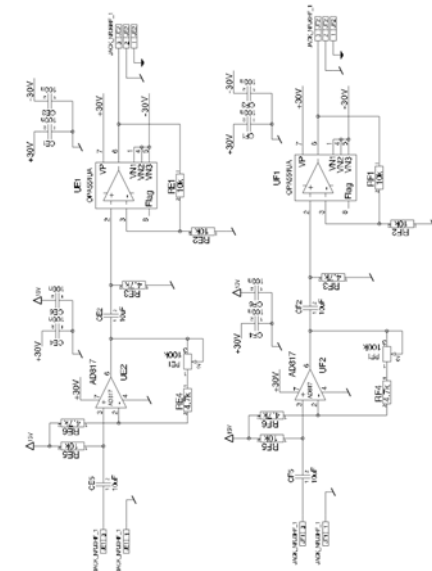

## Examples: SensorScope, Acoustic Tomography

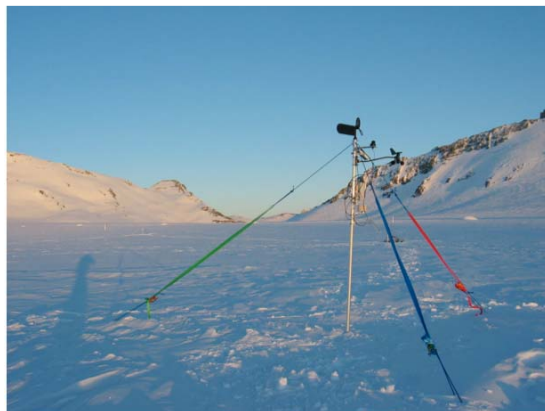

G. Barenetxea et al., *SensorScope: An Environmental Monitoring Network*. In AGU Conference, 2006.  
Ivana Jovanovic, Luciano Sbaiz, and Martin Vetterli, *Acoustic tomography for estimating temperature and wind flow*, ISARS, pp. 69-71, 2006.

# Example: Super-Resolution Imaging

## Personal experience with my PhD thesis work:

- First and second conference paper - 2003
  - Not reproducible
- First journal paper - April 2004
  - Let's make it reproducible...
  - 1 week work
  - Paper with Matlab code, data, figures online
- Second journal paper - Dec 2005
  - Reproducible, of course!
  - 1 day work
  - Paper with Matlab code, data, and figures
- In between (summer 2005), student wrote GUI for Matlab code
- Writing PhD thesis
  - Great, I can recycle my code!
  - Easy to create new figures by changing parameters and axis labels
  - 3 months to write thesis

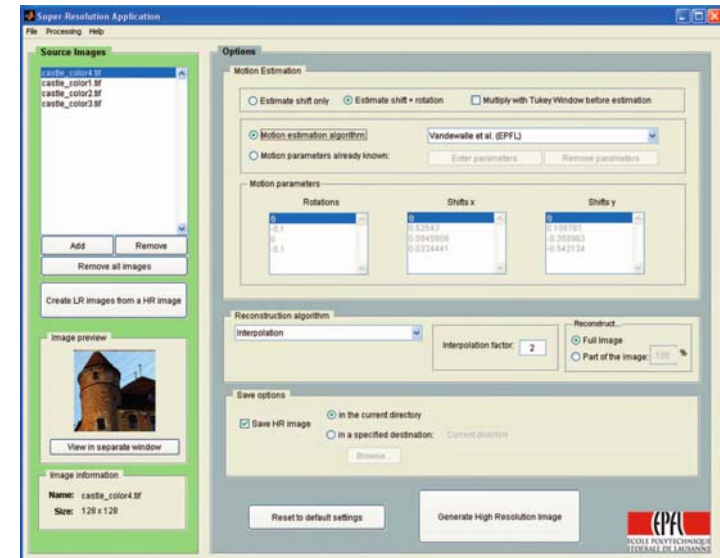

P. Vandewalle, *Super-resolution from unregistered aliased images*, EPFL, 2006.

# Example: Super-Resolution Imaging

## Benefits:

- Efficient reuse of own results
- Nice demo material (using GUI)
- Many downloads
- Nice reactions
  - “When I am beginning to study image super-resolution, I read a lot of papers about it, but I found that I don't know how to realize the algorithms of these paper. Your works help me make great progress. Hope to have more super-resolution algorithms code for us to study. Thanks.”
  - “We're interested in improving the algorithm via our own methodology in registration. We're using your methods as a springboard of research for use in security applications.”
- Collaborations

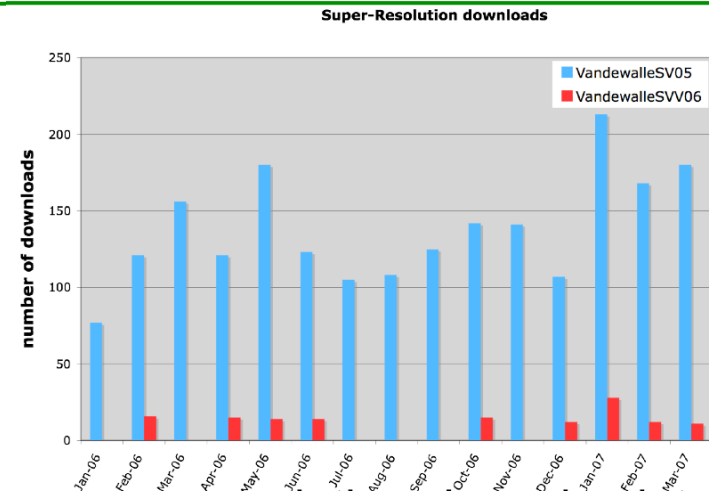

# Reproducibility study

---

## Reproducibility Review Study

- All 134 IEEE Transactions on Image Processing papers from 2004
- Reviewed by 90 reviewers (at least 2 for each paper)
- Questions about reproducibility of algorithms, code, and data

## IEEE TRANSACTIONS ON **IMAGE PROCESSING**

A PUBLICATION OF THE IEEE SIGNAL PROCESSING SOCIETY



[www.signalprocessingsociety.org](http://www.signalprocessingsociety.org)

P. Vandewalle, J. Kovacevic and M. Vetterli (2009) *Reproducible Research in Signal Processing - What, why, and how*. IEEE Signal Processing Magazine, 26 (3). pp. 37-47.

# Reproducibility study

---

- Questions about reproducibility of algorithms, code, and data
  - Reproducibility of the algorithm
    - Is the algorithm described in sufficient detail?
    - Are exact parameter values given?
    - Is there a block diagram?
    - Is there a pseudo-code?
    - Are there proofs for all the theorems?
    - Is the algorithm compared to other algorithms?
  - Reproducibility of the code
    - Are implementation details (programming language, platform, compiler flags, etc.) given?
    - Is the code available online?
  - Reproducibility of the data
    - Is there an explanation of what the data represents?
    - Is the size of the dataset acceptable?
    - Is the dataset available online?

# Reproducibility study

---

- Study Results
  - Algorithm and data are generally well described (84%)
  - 2/3 papers (describing an algorithm) compare their algorithm to other algorithms
  - Half of the articles contain a block diagram or pseudo-code
  - 1/3 have data available online (mostly Lena?)
  - Only 9% have code available online!

ALGORITHM						CODE		DATA		
DETAILS	PARAMETER VALUES	BLOCK DIAGRAM	PSEUDO-CODE	PROOFS	COMPARISON	IMPLEM. DETAILS	CODE AVAIL.	EXPLANATION OF DATA	SIZE DATA SET	DATA AVAIL.
0.84	0.71	0.37	0.33	0.27	0.64	0.12	0.09	0.83	0.47	0.33

---

# Practical considerations

---

Everybody agrees ... so why does it not happen (yet) ?

- It's extra work
- Publishers don't like it, or at least researchers think so (in fact, publishers often allow it)
- You don't get (enough) credit for it
- This gives others an advantage
- You need to disclose everything
- The least publishable increment  $\epsilon$  will increase

See also Victoria Stodden's survey of computational scientists, e.g. in V. Stodden, *Intellectual Property Issues in Publishing, Sharing, and Blogging Science*, ScienceOnline2010 seminar, Jan 2010.

# Software Platforms

---

Various software platforms are used

- General programming languages: C/C++, Java, etc.
- Open source scientific software: Octave, R, SciLab, etc.
- Commercial software packages: Matlab, Mathematica, etc.



Make results as easy to reproduce as possible!

Ideally, a simple mouse click is sufficient...

A wide variety of tools exist

- Makefile
- Madagascar / SCons
- Sweave
- ResearchAssistant (Java-based)

Which software tools can be considered 'standard' ?

# Data Availability

---

- Use of own data vs standardized data sets
- Check rights before putting data online
  - Anonymized data
  - Sample of the data
- Description of data
  - What do they represent ?
  - How were the data acquired ?



# RR Repository

## How to make those data available?

- Some journals allow additional materials linked with the paper
- Repository setup using Eprints: for example rr.epfl.ch
  - Easy setup
  - Web page with reference, full text, code, and data
  - Long-term repository initiatives as opposed to personal web pages

## Who will test reproducibility?

- Publisher: maybe, but expensive
- Reviewers: maybe, but these are voluntary efforts
- You!
  - Let readers mark that they have tested the code, it works, etc.
  - Let readers give comments (and learn from previous comments)

Reproducible Research Repository

Home | Browse by Year | Browse by Publication Type | Search | About

Login | Create Account

Super-Resolution from Unregistered and Totally Aliased Signals using Subspace Methods

This item supports Reproducible Research [Add your evaluation](#) [Leave comments](#) 

Vandewalle, Patrick and Sbaiz, Luciano and Vandewalle, Joos and Vetterli, Martin



Abstract

In many applications, the sampling frequency is limited by the physical characteristics of the components: the pixel pitch, the rate of the A/D converter, etc. A low-pass filter is usually applied before the sampling operation to avoid aliasing. However, when multiple copies are available, it is possible to use the information that is inherently present in the aliasing to

# Impact

---

## **Reproducible Research increases impact**

- Papers available online are cited 3 x more often \*
- Papers with online datasets have 69% more citations \*\*
- It is likely that the same holds true for reproducible research
- Increased visibility
- E.g. more than 200 downloads/month for super-resolution code
- E.g. Red-eye removal paper - with online Java code - most popular download in EPFL database (2nd half 2006)

\* S. Lawrence (2001) Free online availability substantially increases a paper's impact. Nature 411, 521.

\*\* Piwowar HA, Day RS, Fridsma DB (2007) Sharing Detailed Research Data Is Associated with Increased Citation Rate. PLoS ONE 2(3): e308.

# Impact

## Reproducible Research increases impact

Review study was too small for representative results, but highly cited papers do have code and data online

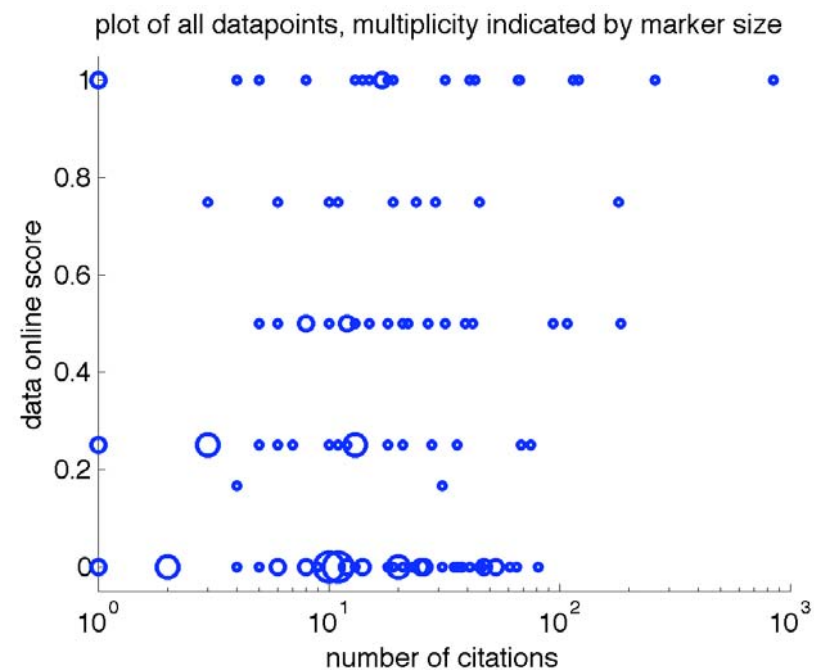
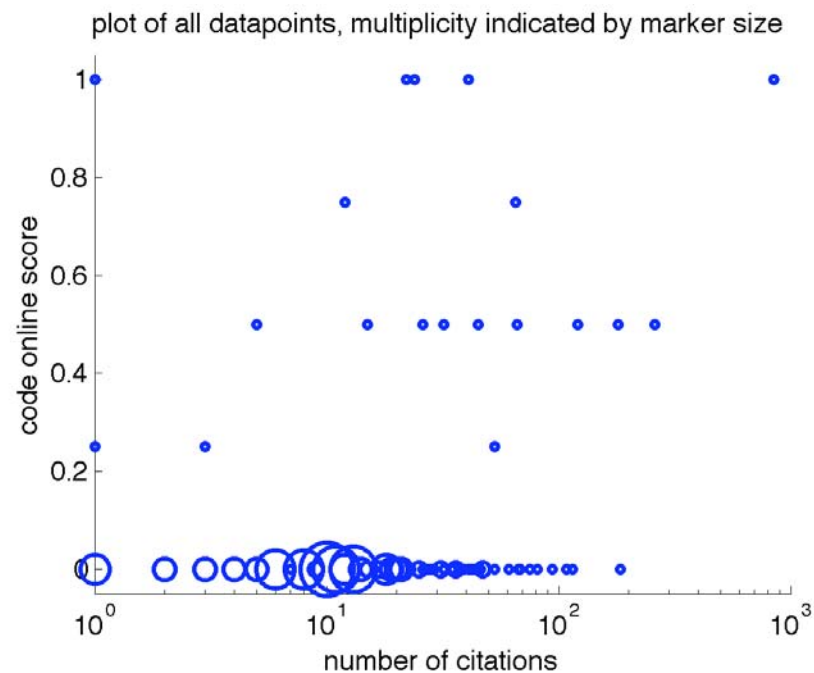

# Conclusions

---

- Reproducible research increases impact
- It helps both yourself and other people
- Today is a good time to start making your research reproducible!

*Standing on each other's shoulders, not on each other's toes.*

*- K. Price, adapted from R. W. Hamming -*

More information:

*<http://www.reproducibleresearch.org>*

*Or contact Patrick Vandewalle*

*[Patrick@reproducibleresearch.org](mailto:Patrick@reproducibleresearch.org)*

# And an example of RR gone awry

## EXPERIENCES WITH REPRODUCIBLE RESEARCH IN VARIOUS FACETS OF SIGNAL PROCESSING RESEARCH

P. Vandewalle<sup>†</sup>, G. Barrenetxea<sup>†</sup>, I. Jovanovic<sup>†</sup>, A. Ridolfi<sup>†</sup>, and M. Vetterli<sup>‡ §</sup>

<sup>†</sup> LCAV - School of Computer and Communication Sciences, EPFL, CH-1500, Lausanne, Switzerland

<sup>§</sup> Department of Electrical Engineering and Computer Sciences, UC Berkeley, Berkeley CA947

### ABSTRACT

How often have you been able to implement an algorithm as it is described in a paper? And when you did, were you confident that you had exactly the same parameter values and results as the authors of the paper? All too often, articles do not describe all the details of an algorithm and thus prohibit an implementation by someone else. In this paper, we describe our experience with reproducible research, a paradigm to allow other people to reproduce with minimal effort the results we have obtained. We discuss both the reproducibility of data and algorithms, and give examples for each of them. The effort required to make research reproducible is compensated by a higher visibility and impact of the results.

**Index Terms**— reproducible research, publishing, source code, open source software

It is also interesting to see how a similar concept was presented by Knuth in 1984 as ‘literate programming’ [7]. Instead of starting from the research results and publications, and adding software to it to make the results reproducible, he presented literate programming as a way of improving the documentation of programs: “Instead of imagining that our main task is to instruct a *computer* what to do, let us concentrate rather on explaining to *human beings* what we want a computer to do.” The result is very similar to what we have in mind as a reproducible research paper.

2.

**Definition.** relevant to 1 data and co

### ABSTRACT

How often have you been able to implement an algorithm as it is described in a paper? And when you did, were you confident that you had exactly the same parameter values and results as the authors of the paper? All too often, articles do not describe all the details of an algorithm and thus prohibit an implementation by someone else.

In this paper, we describe reproducible research, a paradigm to allow other people to reproduce with minimal effort the results that have been obtained. We discuss both the reproducibility of data and algorithms, and give examples for each of them. The effort required to make research reproducible is compensated by a higher visibility and impact of the results.

**Index Terms**— reproducible research, publishing, source code, open source software

## REPRODUCIBLE RESEARCH IN VARIOUS FACETS OF SIGNAL PROCESSING



Kovacevic describes the relation between publishing and reproducible research [4], Vandewalle et al. discuss the use of standard datasets and dataset competitions [5], and Fomel and Hennenfelt describe a practical implementation using SCons [6].

It is also interesting to see how a similar concept was presented by Knuth in 1984 as ‘literate programming’ [7]. Instead of starting from the research results and publications, and adding software to it to make the results reproducible, he presented literate programming as a way of improving the documentation of programs: “Instead of imagining that our main task is to instruct a *computer* what to do, let us concentrate rather on explaining to *human beings* what we want a computer to do.” The result is very similar to what we have in mind as a reproducible research paper.